



ELECTRICAL INSTALLATION GUIDE

SCHNEIDER FAN CONTROL

All installation wiring must conform to your National Electrical Code and meet Local Codes. While we can't guarantee it, we believe that using Envira-North Systems controls and following our instructions will result in an installation that meets those requirements. Code compliance is ultimately the installer's and/or the user's responsibility.

Subject to Changes Without Notification.

ENVIRA-NORTH
SYSTEMS LIMITED

(519) 527-2198
enviranorth.com



TABLE OF CONTENTS

| | |
|---------------------------------------|---------|
| Table of Contents..... | 2 |
| Safety Precautions..... | 2 |
| Reference Acronym Key..... | 3 |
| Included Components..... | 3 |
| Power Requirements..... | 3 |
| Motor Data..... | 4 |
| General Mounting Instructions..... | 4 - 5 |
| Wiring Instructions..... | 5 - 6 |
| Lengths of Motor Cables..... | 7 |
| Wiring Schematics..... | 8 - 9 |
| LED Light..... | 10 - 11 |
| Low Voltage Control Wiring..... | 12 |
| Low Voltage Control Installation..... | 13 - 14 |
| MODBUS Integration..... | 15 |

SAFETY PRECAUTIONS

- DO NOT TURN OFF FAN WHILE IN MOTION USING A DISCONNECT SWITCH!
- All installations must be completed by a qualified person.
- Do not work on live equipment.
- Use of lock-out procedures when applicable is a must.
- Use proper PPE during installation.
- After the VFD has been disconnected from the supply voltage, wait 15 minutes for capacitors to discharge before servicing VFD.
- Close all protective covers and doors prior to and during operation.

This installation guide provides general instructions for the most common installation scenarios. However, due to variations in system configurations, hardware setups, and installation environments, this guide may not cover all possible installation situations. If you encounter issues or your setup differs from the examples provided, we recommend consulting additional resources or seeking assistance from technical support.

REFERENCE ACRONYM KEY

- VFD - Variable Frequency Drive

INCLUDED COMPONENTS

- Variable Frequency Drive.....x 1 pc.
- Galvanized steel mounting platex 1 pc.
- #10-32 x 3/4" machine screwx 4 pcs.
- #10-32 Nyloc nutx 4 pcs.
- #10 Self-tapping screwx 4 pcs.
- M20 split gland & nutx 1 pc.
- 100' Cat5 cable.....x 1 pc.

POWER REQUIREMENTS

| Power Rating | 200 - 240VAC 50/60 Hz - Single Phase | | | 380 - 500 VAC 50/60 Hz - 3 Phase | | | 525 - 600 VAC 50/60 Hz - 3 Phase | | |
|------------------|--------------------------------------|---------|------------------|----------------------------------|---------|------------------|----------------------------------|---------|------------------|
| | Mains Current | | Drive (Output) * | Mains Current | | Drive (Output) * | Mains Current | | Drive (Output) * |
| | At 200V | At 240V | Nominal Current | At 380V | At 500V | Nominal Current | At 525V | At 600V | Nominal Current |
| 1.0 HP (0.75 kW) | 10.1 A | 8.5 A | 4.8 A | 3.6 A | 2.7 A | 2.3 A | 1.5 A | 1.4 A | 1.7 A |
| 2.0 HP (1.50 kW) | 17.6 A | 14.8 A | 8.0 A | 6.5 A | 4.9 A | 4.1 A | 2.6 A | 2.4 A | 2.7 A |
| 3.0 HP (2.20 kW) | 23.9 A | 20.1 A | 11.0 A | 8.7 A | 6.6 A | 5.5 A | 3.7 A | 3.2 A | 3.9 A |

* All VFDs are 3 phase output

MOTOR DATA

| Fan Size | Motor Nameplate FLA Ratings* | | | | | | |
|----------|------------------------------|--------|--------|--------|------------------|--------|--------|
| | Sailfin (Geared) | | | | Gearless Sailfin | | |
| | Motor HP | 230V | 460V | 575V | Motor HP | 230V | 460V |
| 8 FT | 1.0 HP | 3.14 A | 1.57 A | 1.25 A | 2.0 HP | 5.60 A | 2.80 A |
| 12 FT | | | | | | | |
| 16 FT | 1.5 HP | 4.20 A | 2.10 A | 1.68 A | | | |
| 20 FT | 2.0 HP | 5.60 A | 2.80 A | 2.24 A | | | |
| 24 FT | | | | | | | |

* Motor manufacturer nameplate ratings may change without notice.

Motor is rated with an Insulation Class F; Ensure proper wiring is used as per current electrical codes.

GENERAL MOUNTING INSTRUCTIONS

- Mount the VFD in a vertical position at $\pm 10^\circ$. This is required for proper device cooling.
- Attach the VFD securely to the mounting surface. Use #10 / M5 or equivalent screws minimum. All 4 mounting holes must be utilized.
- The use of washers is recommended with all mounting screws.
- Tighten the fixation screws.
- Use of lock nuts or a thread locker (ex. Blue Loctite 242) is recommended.
- Do not mount the device outdoors.
- Do not mount the device close to heat sources.
- Avoid environmental effects like high temperatures and high humidity as well as dust, dirt and conductive gases.
- Do not mount the device on flammable or combustible materials.
- Install the drive on a solid, vibration-free support.
- Keep foreign objects such as chips, screws or wire clippings from getting into the device.
- Verify correct seat of seals and cable entries to avoid contamination and humidity.

CLEARANCES

- Maintain a minimum of 4 inches (100 mm) of clearance on all sides, and front of the device to facilitate the required cooling.

TEMPERATURES

| | Temperature | | Comments |
|-----------|-------------|-----------|------------------|
| Storage | °C | -25...70 | |
| | °F | -13...158 | |
| Operation | °C | -10...40 | Without Derating |
| | °F | 14...104 | |
| | °C | 40...60 | With Derating |
| | °F | 104...158 | |

WIRING INSTRUCTIONS

DANGER

HAZARD OF ELECTRIC SHOCK, EXPLOSION, OR ARC FLASH

Before applying voltage to and configuring the product, verify that it is properly wired.

Failure to follow these instructions will result in death or serious injury.

- Verify installation is in compliance with all local and national electrical code requirements.
- Only use cables with insulator heat resistance of 75°C (167°F) minimum.
- Use of a shielded cable to meet the requirements of Category C2 or C3 according to the standard IEC 61800-3.
- The size of the input and output wiring depends on the wire length and the current draw of the motor.
- Use a continuous run of wires from the motor to the VFD (no splices or connections.)

IMPORTANT CONSIDERATIONS:

- VFD input and output power cables **MUST NOT** be run in the same conduit.
- VFD control cables **MUST NOT** be run in the same conduit with any power cables.
- Output cables of more than one VFD **MUST NOT** be run in the same conduit.

EQUIPMENT GROUNDING

A separate insulated ground must be provided to each VFD from the electrical panel. This will reduce noise from being radiated into other equipment.

Ensure that the resistance from the VFD to Ground is 1 ohm or less.

When grounding several VFDs, each must be directly connected to the supply panel.

Do not loop ground cables or connect them in series.

A grounding wire from the VFD to the motor must be present and connected to both devices. Conduit or shielding is not sufficient.

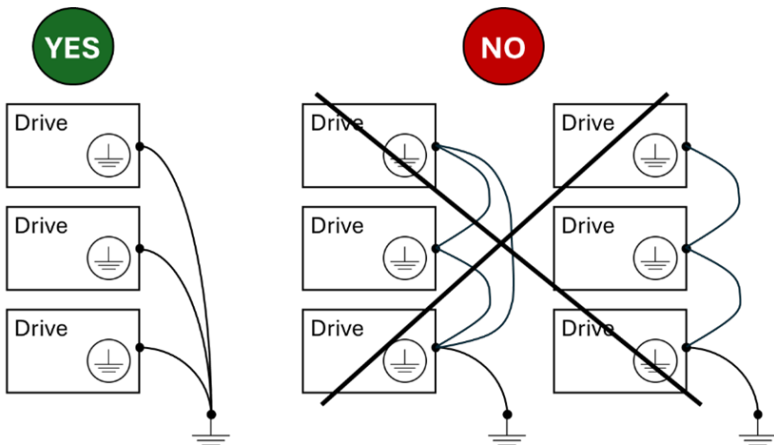

LENGTH OF MOTOR CABLES

An effort must be made to reduce to a minimum the distance between motor and drive.

| Cable Length Between The VFD & Motor | | | |
|--------------------------------------|--------------------------------------------------|-------------------------------------|---------------|
| Length | Line Voltage | Cable Length | VFD HP Change |
| Acceptable Normal Length | No additional devices required with standard VFD | | |
| | 230 VAC | Max. 250' | No HP Change |
| | 460 VAC | Max. 150' | No HP Change |
| | 600 VAC * | Max. 25' | No HP Change |
| Above Normal Length | Load reactor required (1.5% or 3% impedance) (#) | | |
| | 230 VAC | 250' - 400' | No HP Change |
| | 460 VAC | 150' - 250' | No HP Change |
| | 600 VAC * | 25' - 100' | No HP Change |
| Extreme Length | DV/DT filter required, upsize VFD HP (#) | | |
| | 230 VAC | Greater than 400' & less than 1000' | + 1 HP |
| | 460 VAC | Greater than 250' & less than 1000' | + 1 HP |
| | 600 VAC * | Greater than 100' & less than 1000' | + 1 HP |

* 600 VAC not available for Gearless fan models.

(#) Switching frequency must be adjusted to 4 kHz when any output reactor/filter is used.

CONSEQUENCES OF LONG CABLE LENGTHS:

When VFDs are used with motors, a combination of fast switching transistor and long motor cables can cause peak voltages up to twice the DC link voltage. This high peak voltage can cause premature aging of motor winding insulation which leads to motor breakdown.

LOAD REACTOR AND dV/dT FILTER:

The above table; the cable length includes vertical distances. There will be 3 different classes of distance having distance measurement, addition of load reactor or dV/dT filter and change in the horsepower rating of the VFD. In cases of adding either a load reactor or filter, the device has to be installed close to the VFD (within 6-10 feet) on the Load Side of the VFD.

When using VFD's, special care must be taken as VFD manufacturers have noted that excessive reflective voltages are generated due to the distance. The voltages may shorten the life expectancy of the motors and VFDs.

WIRING SCHEMATIC

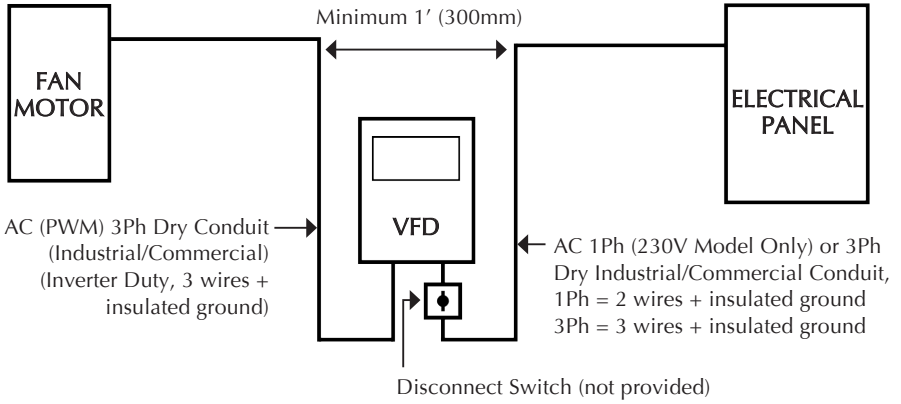

CONNECTIONS: VFD

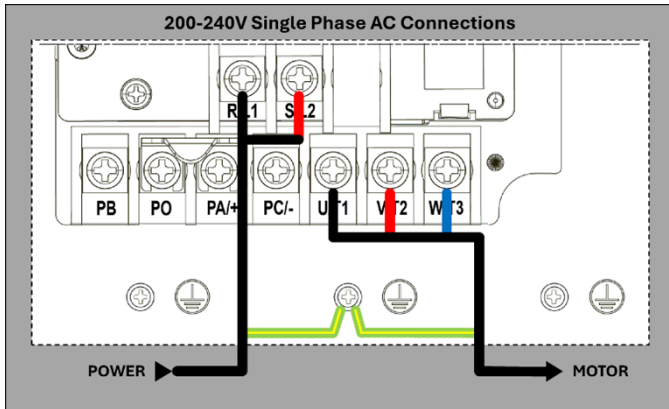

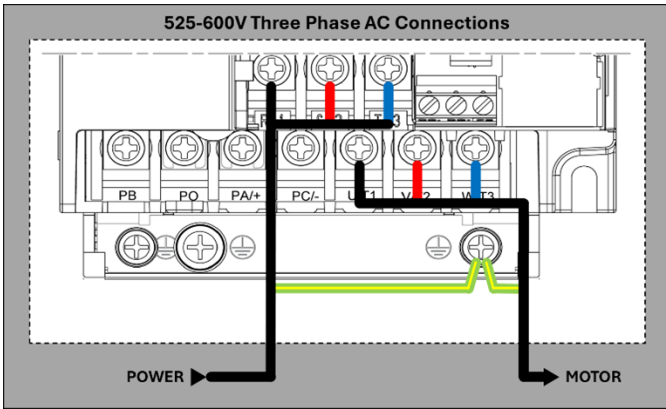
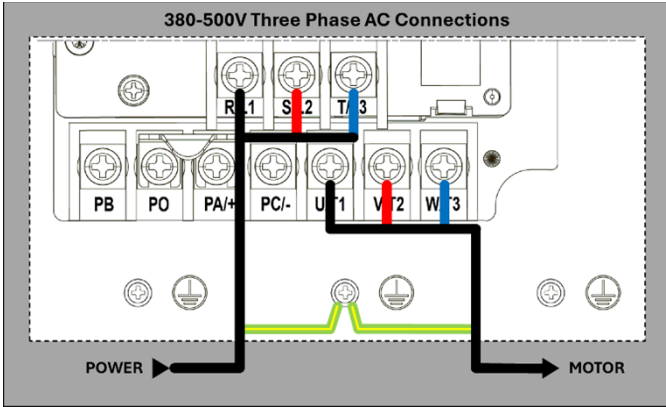

CONNECTIONS: MOTOR

230/460V

575V

(Geared fans only)

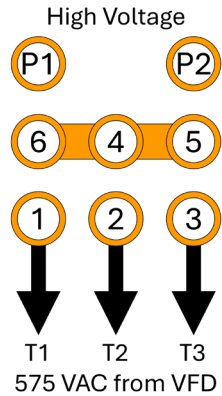
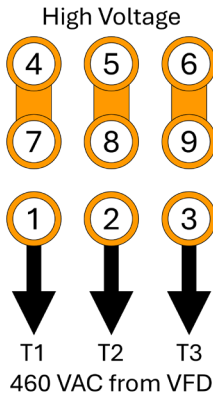
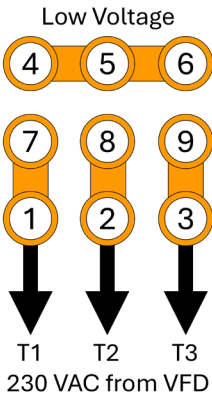

LED LIGHT

CONTROL WITH VFD

The LED light on the Gearless Sailfin fans can be controlled through the VFD if the fan is being integrated with the Smart-Air (single or multi-fan) or Touch-Air controllers.

The below illustration shows the proper connections to the VFD I/O terminals from the factory wires on the LED light.

*Depending on the mounting location of the VFD, additional wiring may be required to complete the connection from the light to the VFD.

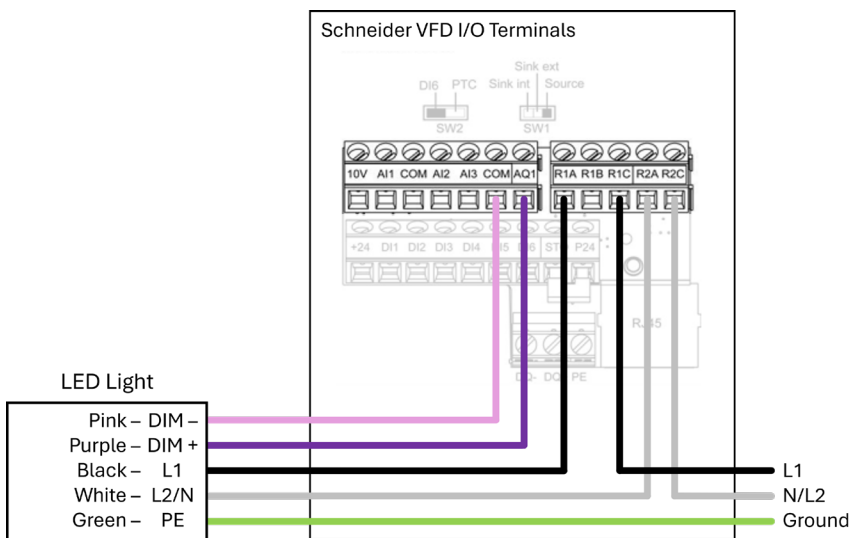

EXTERNAL SWITCH WITHOUT DIMMING

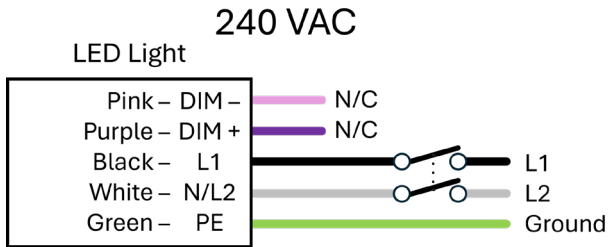
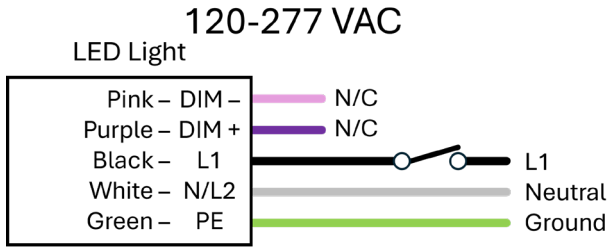

EXTERNAL SWITCH WITH DIMMING

A 0-10V LED compatible Dimmer switch must be used to control the light with dimming.

Leviton DS710-10Z or Lutron DVSTV-WH are examples of suitable 0-10V dimmer switches.

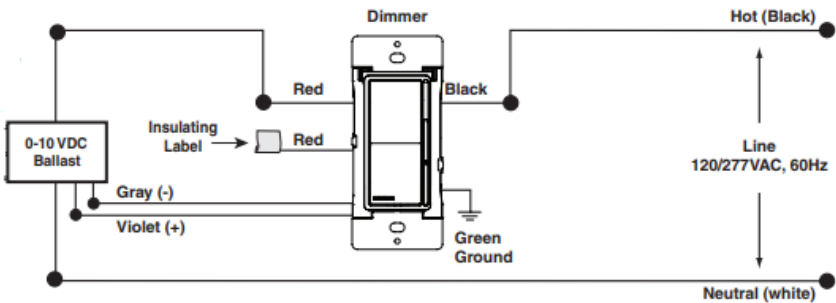

LOW VOLTAGE CONTROL INSTALLATION

OPERATING INSTRUCTIONS (LVC)

1. DO NOT TURN OFF THE FAN WHILE IN MOTION USING A DISCONNECT SWITCH.
2. Make sure the toggle switch labelled “TFD-1 / Manual” switch is in the ‘MANUAL’ position.
3. Use the speed potentiometer to adjust the fan’s speed
4. Always use the Red Stop button (on the right of the Low Voltage Controller) to turn off or stop the fan.
5. To reverse the direction of the fan while in motion, use the toggle switch labelled “Forward / Reverse.”



SETUP OF TFD TEMPERATURE CONTROLLER (OPTIONAL)

To adjust the TFD:

- Rotate the Selector dial to position (1) Set Point
- Rotate the Adjustor dial to desired set point temperature (Example 20°C)
- Rotate the Selector dial to position (2) Modulation Band
- Rotate the Adjustor dial to desired modulation band (Example 10°C)
- Rotate the Selector dial to position (3) Minimum Ventilation Off
- Rotate the Adjustor dial to desired minimum (Example 5°C)

In the examples above, from start-up, the fan will start to turn only if the interior temperature reaches 20°C. The speed that will be indicated on the fan controller should be approximately 27%. As the temperature rises in the building, the fan will increase speed until the temperature

LOW VOLTAGE CONTROL INSTALLATION

reaches the end of the modulation band. At 30°C (set point + modulation band) the fan will be at its maximum (100%) speed.

As the temperature decreases the speed will decrease until you reach the set point (20°C). At that point the speed will be at its minimum. As the temperature decreases below the set point, the fan will continue to operate at its minimum rate until you reach 15°C (set point minus the minimum ventilation off). Below this point of 15°C the fan will stop and will stay in the off condition until the temperature rises to the set point – minimum off (15°C) and then the cycle repeats itself.

The minimum speed has been programmed to 15 Hz or 27%. DO NOT lower it pass this limit otherwise your warranty will be void. Lowering the speed below 15 Hz or 27% will cause the motor to overheat because the motor will not draw enough air to cool down at these low speeds.

OPERATING INSTRUCTIONS (LVC + TFD)

1. DO NOT TURN OFF THE FAN WHILE IN MOTION USING A DISCONNECT SWITCH.
2. Make sure the toggle switch labelled “TFD-1 / Manual” switch is in the ‘TFD-1’ position.
3. Always use the Red Stop button (on the right of the Low Voltage Controller) to turn off or stop the fan.
4. To reverse the direction of the fan while in motion, use the toggle switch labelled “Forward / Reverse.”



MODBUS INTEGRATION

MODBUS CONTROLS (SmartAIR/TouchAIR)

- For full integration instructions with Modbus controls, refer to the manual included with the controller ordered.

For ease of installation, the Modbus controls utilize Cat5 cables to facilitate the integration of the VFDs with the control.

Under ideal conditions, the controls can support:

| Controller | Number of Fans | Max Cable Length * | Power Supply |
|-----------------------|----------------|--------------------|-----------------------|
| SmartAIR (Single Fan) | 1 | 100' | VFD |
| SmartAIR Multi-Fan | 10 | 1000' | External |
| TouchAIR | 20 | 4000' | Internal Power Supply |

* Local environmental conditions such as electro-magnetic interference may reduce these lengths. These conditions may require the use of other equipment such as shielded cable or signal repeaters in order to mitigate this interference. The VFDs include a 100' length of Cat5 cable. This cable may not be adequate for all installations.

If cable lengths between devices exceeds 100', bulk cable must be used to create uninterrupted cables between the devices. The only permitted junctions in the network are couplers or splitters at each device.

Tel: 1-519-527-2198 Fax: 1-519-527-2560
Toll Free: 1-866-771-7766

bigair@enviranorth.com

139 Sparling St. P.O Box 668
Seaforth, Ontario
Canada N0K 1W0

enviranorth.com