



Aisle-Air FANS



INSTALLATION GUIDE

EN060X3400 & EN060X3401

Subject to Changes Without Notification.

ENVIRA-NORTH
SYSTEMS LIMITED

(519) 527-2198
enviranorth.com
EN921X8235



AISLE-AIR FAN COMPONENTS DIAGRAM

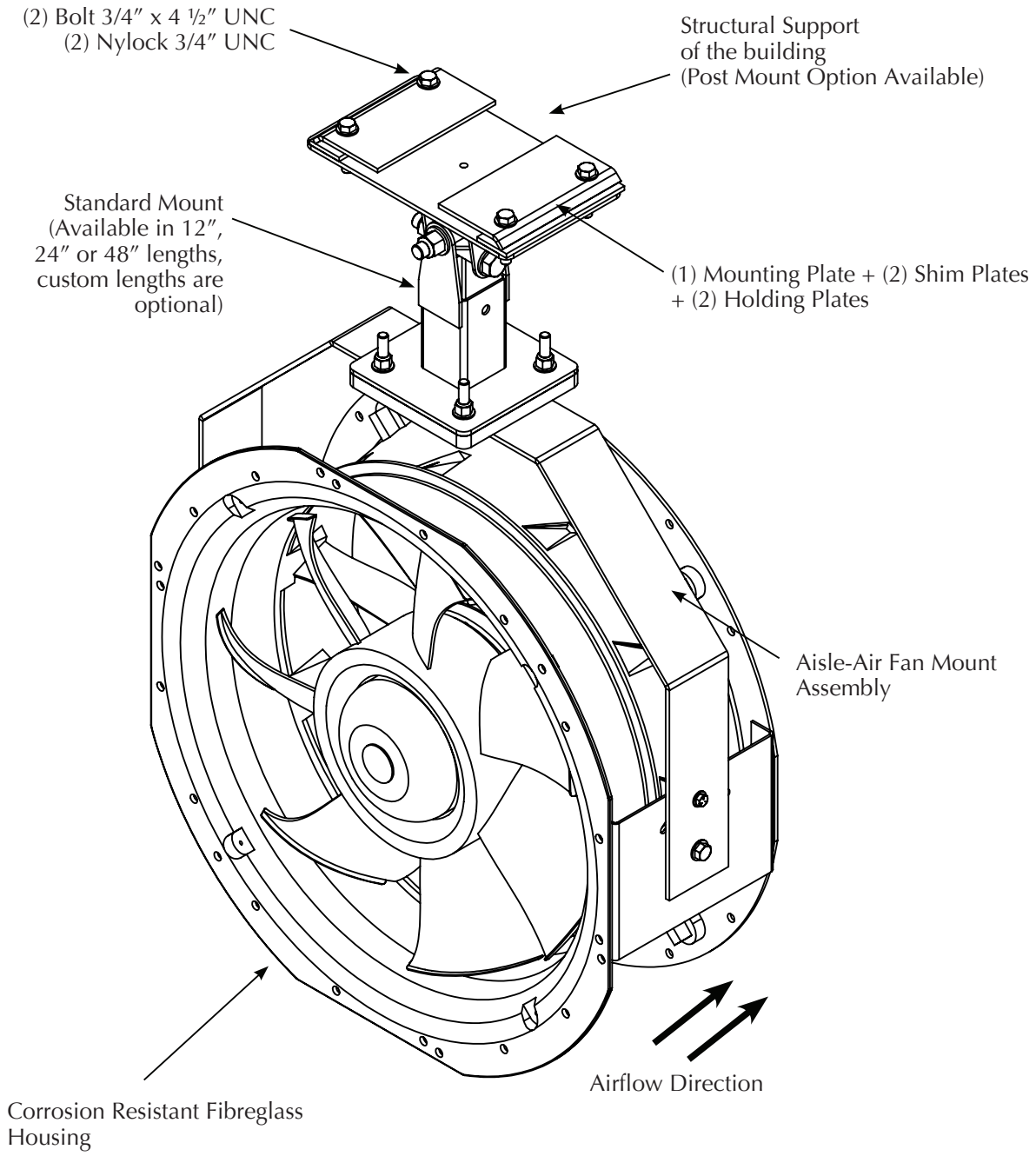

**Optional OSHA Compliant Guard Available

Note: All bolts are "Grade 5 UNC"
 FT = Fully Threaded
 (#) = Quantity Supplied

TABLE OF CONTENTS

INSTALLATION & COMPONENTS	2 - 12
Components Diagram.....	2
Tools Required to Install the Product.....	3
Required Steps Before Installation.....	3
Mounting Applications.....	4
Standard Mount.....	5
Extensions.....	6
Aisle-Air Assembly Drawing.....	7
Assembling the Fan.....	8 & 9
Aisle-Air Spec Drawing.....	10
Electrical Connections.....	11
DOCUMENTATION	12 - 15
Recommended Maintenance Schedule.....	12
Recommended Maintenance Checklist.....	13
Three Year Warranty.....	14 & 15

TOOLS REQUIRED TO INSTALL PRODUCT

- Level
- Cable cutters (for stainless steel aircraft cable)
- Ratchet or impact gun
- Basic imperial socket set up to 3/4"
- Basic imperial wrench set
- Lifting devices or scaffolding

REQUIRED STEPS BEFORE INSTALLATION

- Check to see if you have all the tools required for the installation.
- Verify that all fan components were received.
- Check drawings and layouts provided to locate where the Aisle-Air Fan is to be installed.
- Take note of direction of airflow to ensure proper orientation of fan.
- Ensure work area is safe and that all security, policies and procedures for the facility are met.
- Inspect the lift device or mobile platform.
- Each person installing the Aisle-Air Fan must use a safety harness at all times.
- Other safety requirements may be required for installation.
- All workspace safety requirements, lock out procedures and hoarding of construction zone for the assembly and installation must be met and followed.

DIFFERENT MOUNTING APPLICATIONS

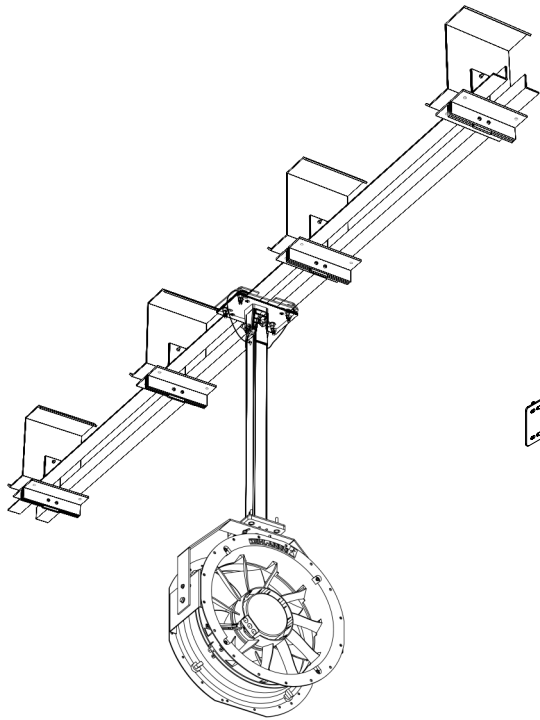

PURLIN Z MOUNT

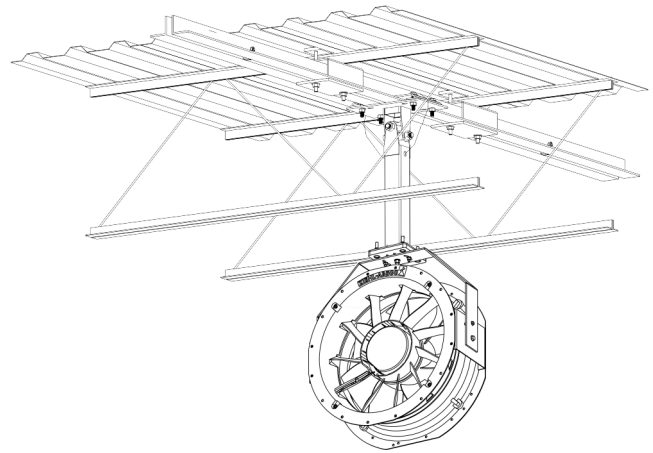

OWSJ MOUNT

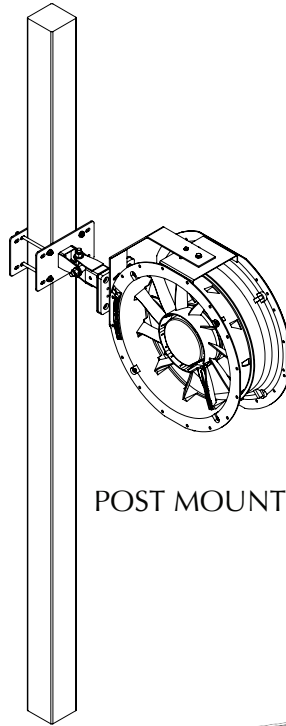

POST MOUNT

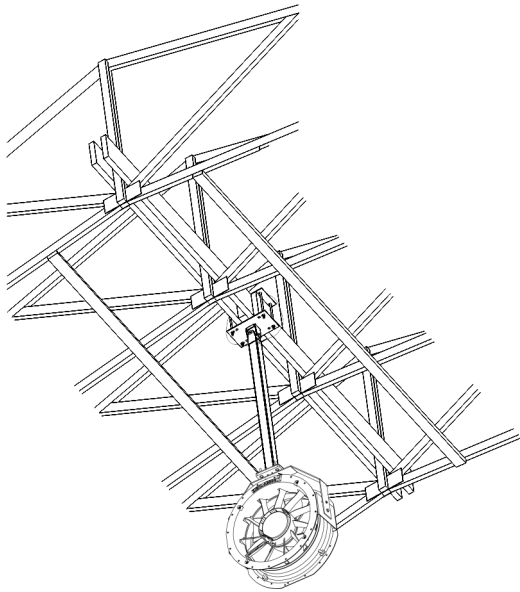

WOOD BEAM MOUNT

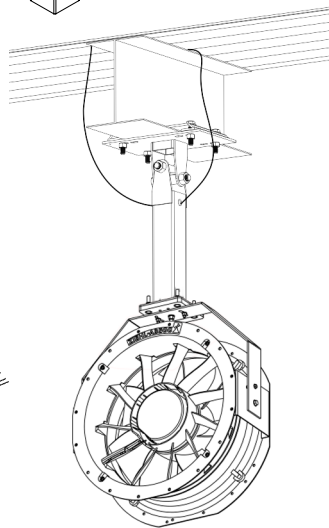

I BEAM MOUNT

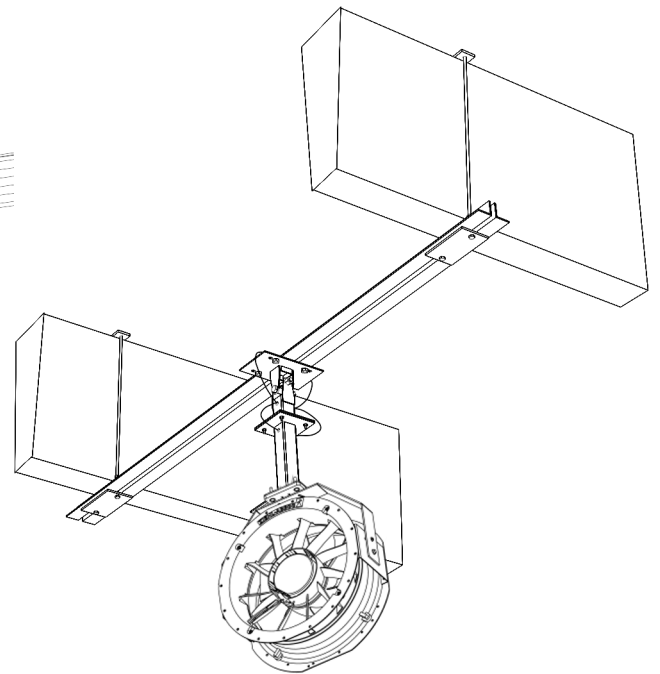

CONCRETE BEAM MOUNT

NOTE: The following mounting applications are representations only and are subject to change without notice.

STANDARD MOUNT INSTALLATION

A Standard Mount package is used with all Aisle-Air Assemblies (except "Wood" Beam Mounting). Standard drop mounts of 12", 24" and 48" are available.

THE PACKAGE INCLUDES:

- (2) mfg "I" Beam clamps
- (2) mfg "I" Beam spacers (may or may not be required for assembly)
- (1) Upper Pivot Plate
- (1) Upper Pivot (pre-assembled)
- (1) Stem for 12", 24" & 48" packages
- (4) Bolts, Nuts & Washers
- (1) Cable 3/16" SS (Length 6.5 ft)
- (4) Cable Clamps 3/16" (not shown)

NOTE: Spacer may or may not be required.
This is dependent upon the thickness of the support structure.

INSTALLING THE MOUNT

1. Sandwich the "I" Beam or OWSJ Beam between the mfg "I" Beam clamps and the upper pivot plate. Insert the mfg "I" Beam spacers if required.
2. Insert the bolts, washers and tighten the nylocks. (Fig.8)
3. Position the safety cable as per Fig.8, loop at both ends.
4. Fasten cable clamps as typical cable clamp installation (Fig.9) Cable should be relatively snug.

TYPICAL CABLE CLAMP INSTALLATION

When placing cable clamps on the wire, it is imperative that the U-bolt side of the clip is placed on the short turn back side and the saddle goes on the long side (the "live" end).

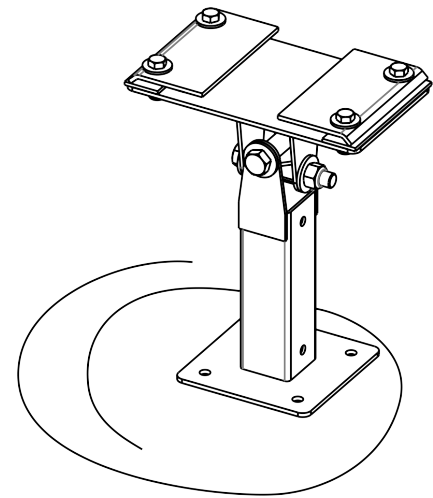

FIG.7

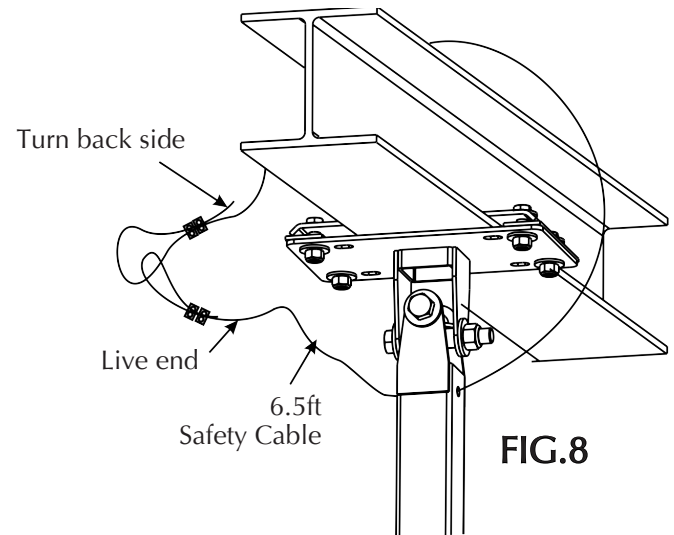

FIG.8

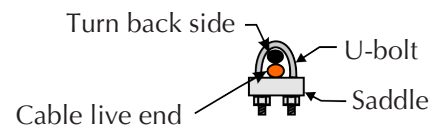

FIG.9

EXTENSION INSTALLATION (IF REQUIRED)

THE PACKAGE INCLUDES:

- (1) Extension (standard 2 ft or 4 ft)
- (4) Bolts $\frac{1}{2}$ " x $1\frac{1}{2}$ " UNC
- (8) Washers Flat $\frac{1}{2}$ "
- (4) Nylocks $\frac{1}{2}$ " UNC
- (1) Cable $\frac{3}{16}$ " SS
(Length 3 ft)
- (4) Cable Clamps $\frac{3}{16}$ "

Depending on your assembly, your package may include an extension. The extension with the standard mount will make up the overall drop length.

If a specific drop distance is required, a custom extension may be an option and can be ordered.

INSTALLING THE EXTENSION

1. Fasten top plate of extension to the bottom plate of the standard mount using $\frac{1}{2}$ " bolts, nuts and washers.
2. Position the safety cable as per Fig.11, loop at both ends.
3. Fasten cable clamps 2 per end and as per typical cable clamp installation (Fig.9). Cable should be relatively snug.

Every connection between components (mounts, extensions and fan frame) must include a safety cable as shown throughout this manual.

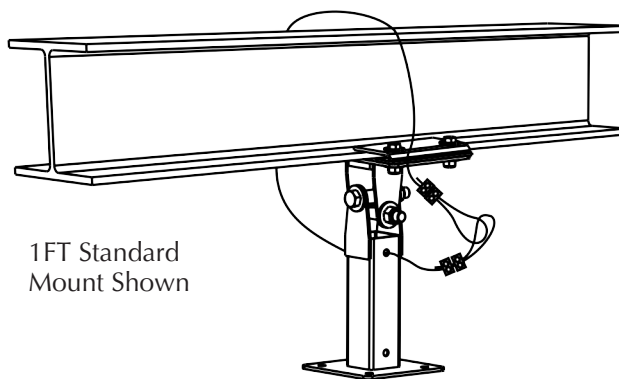

24" or 48" Standard Extensions are Available

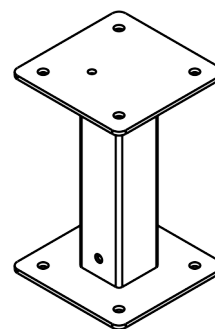

FIG.10

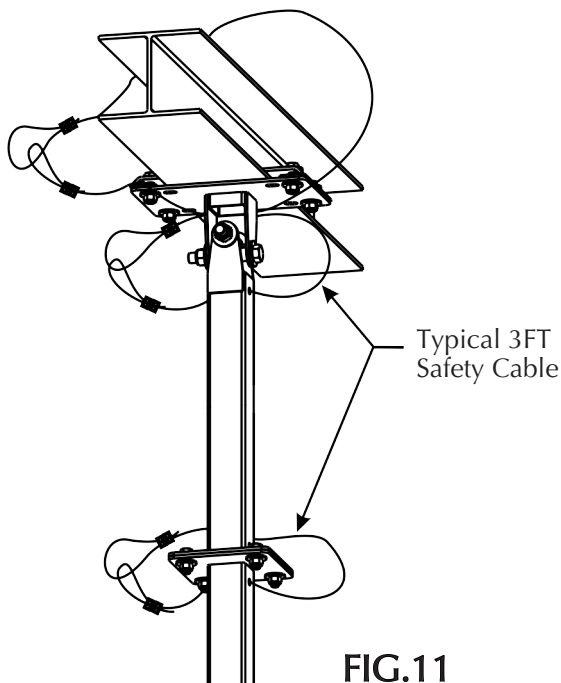
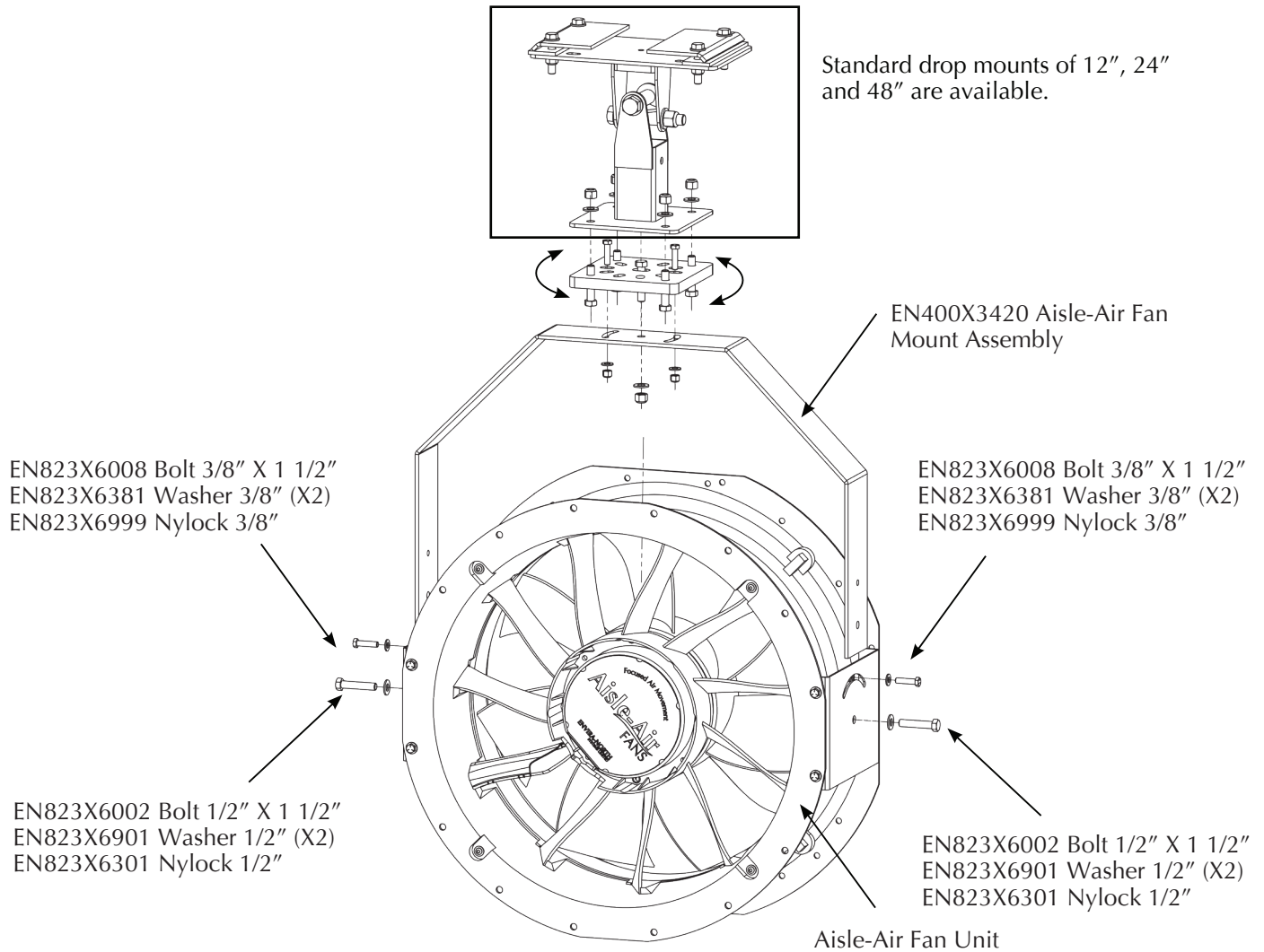

FIG.11

AISLE-AIR ASSEMBLY DRAWING



ASSEMBLING THE AISLE-AIR

THE PACKAGE (36" X 36" X 12") INCLUDES:

(1) Aisle-Air Fan Unit

(1) Aisle-Air Hardware Package

- EN823X6002 Bolt 1/2" X 1 1/2" (X6)
- EN823X6901 Washer 1/2" (X12)
- EN823X6301 Nylock 1/2" (X6)
- EN823X6008 Bolt 3/8" X 1 1/2" (X4)
- EN823X6381 Washer 3/8" (X6)
- EN823X6999 Nylock 3/8" (X4)
- EN823X6950 Safety Cable 3/16" (4FT)
- EN823X6952 Cable Clamps 3/16" (X4)



1. The EN400X3420 Aisle-Air Fans Mount Assembly has several position options for mounting the fan. Simply rotate to your desired angle and install the 2 3/8" X 1 1/2" bolts. This should be done before mounting the fan.



2. The side mount plates come pre-installed on both sides of Aisle-Air unit. Attach the EN400X3420 Aisle-Air Fans Mount Assembly to the Aisle Air unit using the EN823X6002 Bolt 1/2" X 1 1/2", EN823X6901 Washers 1/2" (X2) and EN823X6301 Nylock 1/2" in the lower hole on each bracket. Tighten hardware.



3. Install the EN823X6008 Bolt 3/8" X 1 1/2", EN823X6381 Washers 3/8" (X2) and EN823X6999 Nylock 3/8" in the upper holes on each bracket.

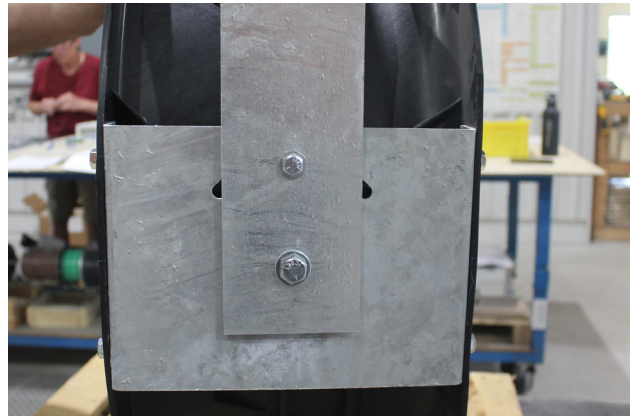

4. The EN400X3420 Aisle-Air Fans Mount Assembly can now pivot freely. Once a position is selected, tighten the EN823X6999 Nylock 3/8" to lock it in place.



5. Install the selected mount (12", 24" or 48") to the EN400X3420 Aisle-Air Fans Mount Assembly using the remaining EN823X6002 Bolts 1/2" X 1 1/2" (X4), EN823X6901 Washers 1/2" (X8) and EN823X6301 Nylocks 1/2" (X4). Secure the EN400X3420 Aisle-Air Fans Mount Assembly to the mount by wrapping the EN823X6950 Safety Cable 3/16" (4FT) around the EN400X3420 Aisle-Air Fans Mount Assembly and the mount. Secure using the EN823X6950 Cable Clamps 3/16" (X4) by looping the ends.
6. The Aisle-Air Fan is now ready to hang!

ELECTRICAL CONNECTIONS

200-240VAC or 380-480, 3 Phase, Motor Connection Diagram w/ Modbus Control

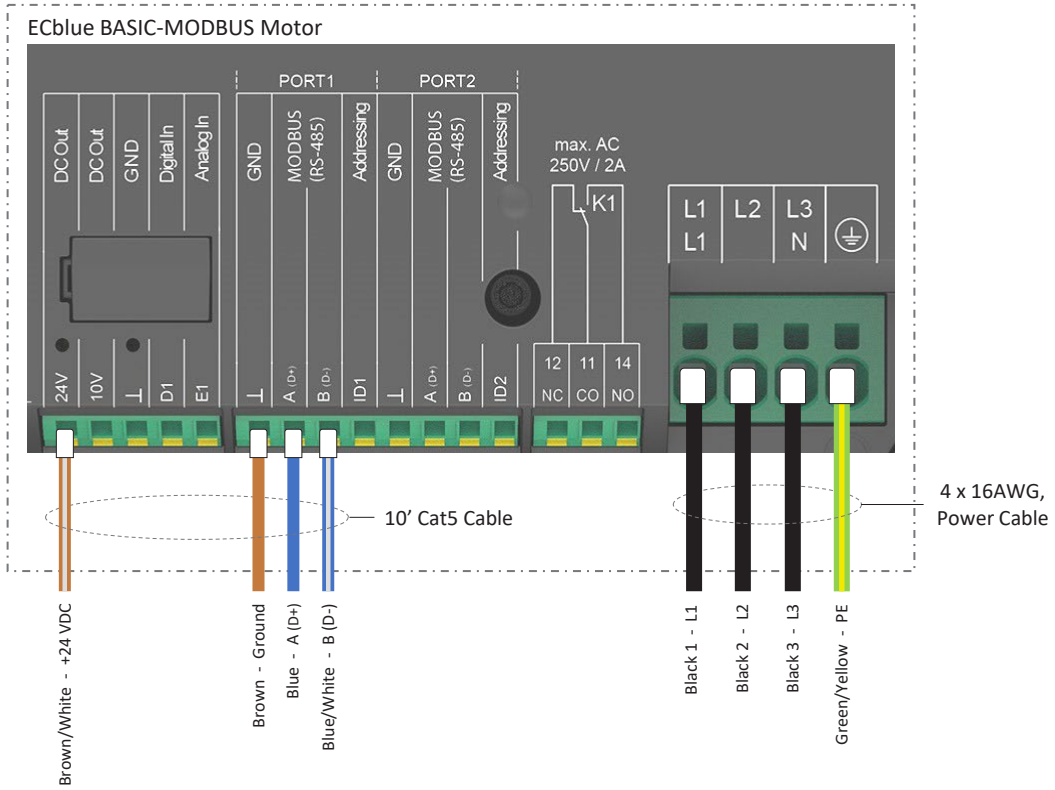

RECOMMENDED MAINTENANCE SCHEDULE

1. No maintenance shall be done on the fan or mount while it is in operation or powered.
2. No maintenance shall be done on the fan controller while powered unless the task involves reprogramming or troubleshooting the electrical system.
3. No maintenance shall be done within a 6m horizontal radius of the fan and 4 ft below while it is in operation.
4. While doing maintenance on the fan, mount, or guy wires, a safety barrier shall be erected at a radius of 6m of the centre of the fan.
5. The fan controller shall be locked out while maintenance is ongoing on the fan, mount, or guy wires.
6. All personnel working on the fan, mount, or guy wires, shall wear the appropriate personal safety equipment as mandated by local, provincial, and national regulations.
7. A risk assessment shall be performed before any maintenance is done on the fan, mount, guy wires and fan controller.
8. A tailboard meeting shall be performed before any work is done. A checklist shall be completed and shall include any emergency contacts for the area.

DROP / MOUNTING

The drop and mounting system is designed to prevent vibration or horizontal movement from being transferred back into the building structure. The system is easily installed in almost any building and allows fans to hang level from beams.

MAINTENANCE SCHEDULE

Initial Six Months

- Physical check of fan guy wires, tighten clamps if required
- Check all nuts/bolts/clamps (missing/loose/damaged)
- Physical check of safety cable, tighten clamps if required

After Eighteen Months Thereafter

LIMITATION OF WARRANTY & LIABILITY

Three Year Limited Warranty

The Aisle-Air fans are of industrial grade construction and should provide many years of virtually maintenance-free use.

Envira-North warrants that this Product will under normal use and service as specified by Envira-North, operate properly and be free of defects in materials and workmanship for a period of three years from the date of purchase by customer. The term “operate properly” in this context applies to mechanical, electrical and structural functions only. No guarantee, unless and except by separate written agreement, is made regarding dimensions of air movement generated or the effectiveness of this Product for its intended purpose.

Labour Warranty will cover all reasonable costs paid by the customer to an independent contractor (including dealers) to remove, dismantle, reassemble or reinstall any of the warranted Products during the first year that the Product is in service. All costs must be pre-approved by Envira-North prior to the work commencing. All receipts are to be submitted to Envira-North which will be paid upon completion of the installation of the Product and after the return of the failed unit. Envira-North will only issue a credit/cheque to the customer/ dealer and will not be held responsible for paying the independent contractor.

WARRANTY EXCLUSIONS

Please note that the following may or could void any or all of the above listed Warranties.

- Please note that the following may or could void any or all of the above listed Warranties.
- Not following required installation procedures as in installation guide and all other documentation supplied with the fans and related equipment, supplied by manufacturers of individual fan and control components.
- Not following all relevant codes and ordinances, not limited to National Electrical Code, provincial or state and local building codes.
- Not following electrical engineering industry standards regarding approved method of installing solid-state electrical equipment having characteristics of fans and all components included in this product.
- Any modification to installation, product and or controls without written authorization from Envira-North, even if attempting to diagnose and or repair a problem.
- Misuse, abuse, accidents, unreasonable use or Acts of God.
- Incorrect electrical current, voltage or supply.
- Running fans at higher than recommended speeds.
- Re-setting parameters of any control without prior approval from Envira-North.
- Failure to use all installation and mounting hardware supplied by Envira-North.
- Failure to perform periodic maintenance as detailed in the Envira-North installation guide.

Envira-North reserves the right to make the final determination, based on its own evaluation of the components as to whether:

- The problem in question is the result of a defect in design, workmanship or materials and not the result of error, misuse or abuse on the part of the customer as stated above.
- Whether the problem or defect is material and requires action under this Warranty.
- Whether the remedy of repair or replacement is appropriate.

Envira-North will not be responsible for remedial work necessary to correct installation procedures that do not conform to those established by the instructions, codes and standards, regardless of when the installation occurred.

With regard to electrical and electronic components provided by Envira-North that comprise part of the Products, including motors, motor drives and HMI's, Envira-North relies on the determination by the original manufacturer as to whether the failure of such component was the result of a defect. If the manufacturer of such component determines that there was no defect and therefore refuses to cover it under warranty, Envira-North likewise will not warranty such item unless Envira-North determines that the failure of such electrical or electronic component was the result of a defect of design, workmanship or material within some other part of the products.

WARRANTY DURATION

With respect to replacement or repair rendered, Envira-North warrants that the parts replaced or repaired will operate properly and be free from defects in materials and workmanship for a period of 90 days from the shipment date of the replacement products to the customer, or for the remainder of the original Warranty period, whichever is longer.

WARRANTY CLAIM INSTRUCTIONS

1. Contact your original dealer/salesman of the purchase when you first notice problem with the Product.
2. It will be the responsibility of the dealer or salesman to assist the customer in determining what Product is causing the problem.
3. If they cannot diagnose the problem, they are to contact Envira-North with all the necessary information.
4. The appropriate department will then be in contact with the customer to determine the cause of the problem.
5. Once diagnosed, submit a Purchase Order for a replacement component complete with price.
6. Replacement component will be shipped out upon receipt of the PO. This PO allows for an order to be established in the Envira-North System.
7. Once the units have been changed over, submit all pre-approved costs to Envira-North for payment.
8. All items being returned for warranty consideration will be required to arrive at 139 Sparling Street,

Seaforth, Ontario, Canada, N0K1W0, no later than 45 days from the date your RGA (Return Goods Authorization) is issued. If the goods do not arrive back to us within that period, the warranty coverage will be declined. Exceptions may be granted but will require written approval from Envira-North Management prior to the 45-day period expiring.

9. No credits or cheques will be issued until all original products are received back at Envira-North or unless Envira-North directs otherwise.

Tel: 1-519-527-2198 Fax: 1-519-527-2560
Toll Free: 1-886-771-7766

bigair@enviranorth.com

139 Sparling St. P.O Box 668
Seaforth, Ontario
Canada N0K 1W0

enviranorth.com

